

PRINCIPAL ARTERIAL SECTION

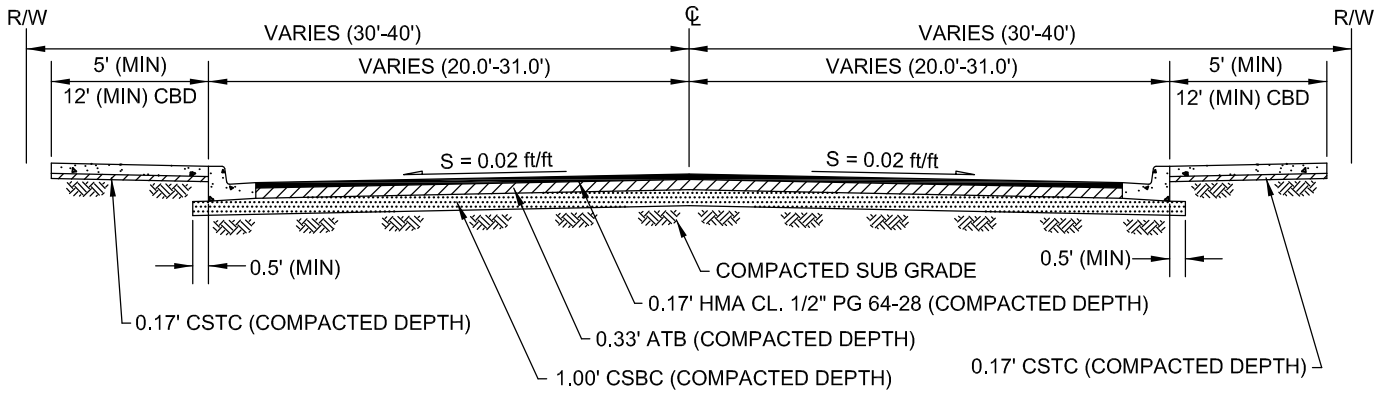

MINOR ARTERIAL SECTION

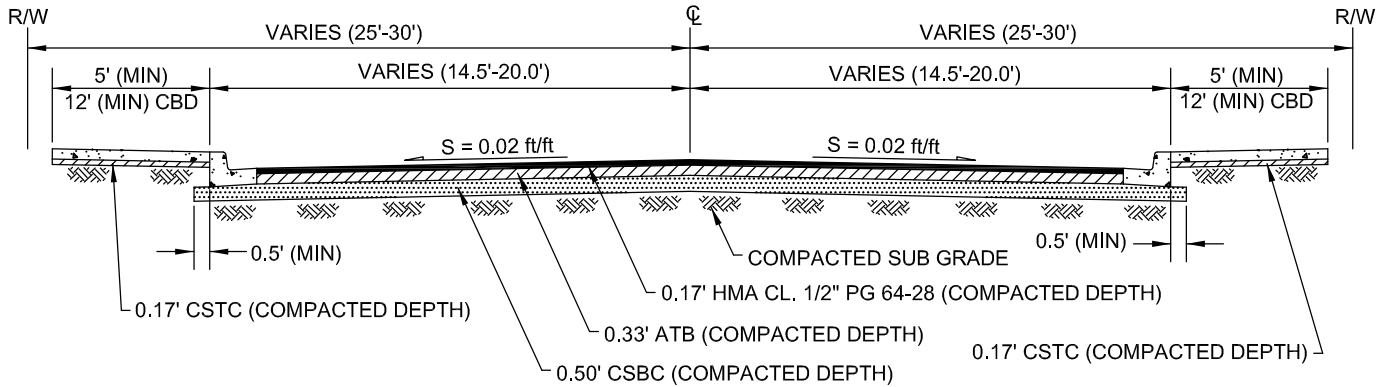

COLLECTOR ARTERIAL SECTION

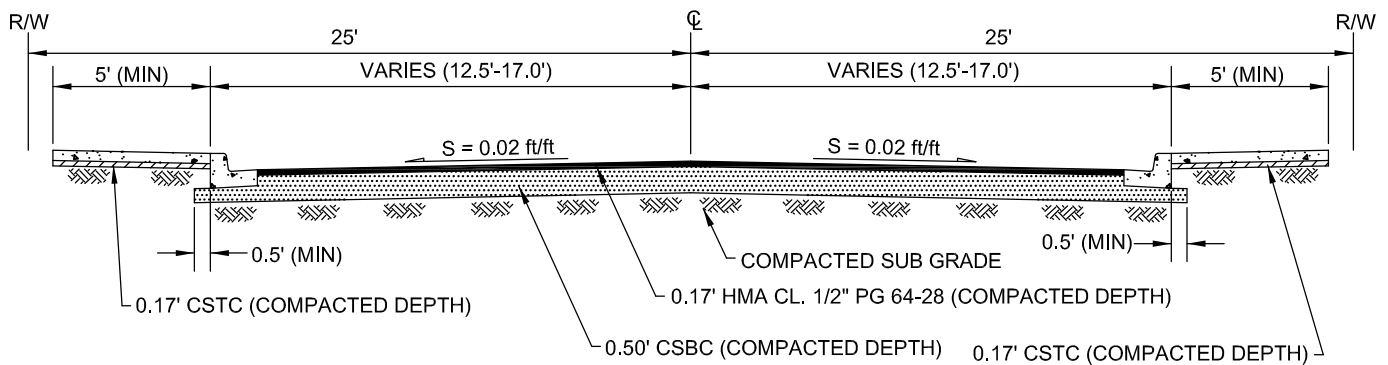

RESIDENTIAL SECTION



City Of Yakima
Engineering Division

129 North Second Street
Yakima, Washington

City of Yakima - Standard Detail
ROADWAY SECTIONS

NOT TO SCALE
Revision 11-2008

R3