

## ASPHALT CONCRETE SURFACING

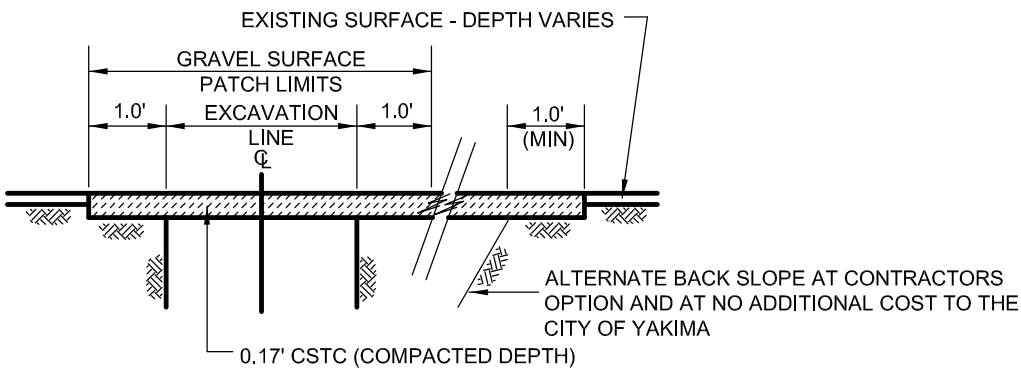

## GRAVEL SURFACING

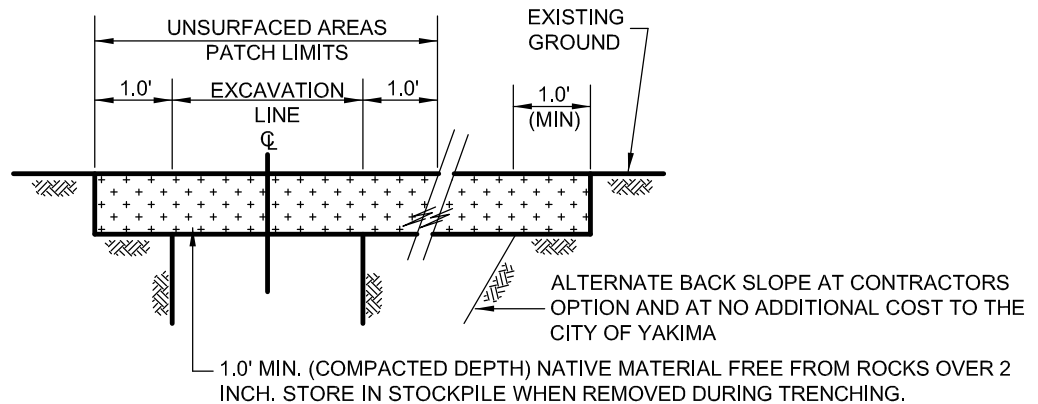

## UNSURFACED AREAS

### NOTES

1. CONTRACTOR SHALL BE RESPONSIBLE FOR ALL SURFACE RESTORATION INCLUDING WIDER REPAIR SECTIONS RESULTING FROM ALTERNATE BACK SLOPE AT TRENCH SIDES.
2. CONTRACTOR SHALL BE AWARE THAT GEO-TEXTILE-FABRIC MAYBE REQUIRED BY THE ENGINEER IN CERTAIN APPLICATIONS.



City Of Yakima  
Engineering Division

129 North Second Street  
Yakima, Washington

City of Yakima - Standard Detail  
**TYPICAL SURFACING**

NOT TO SCALE  
Revision 11-2008

R7