

MONUMENT CASE

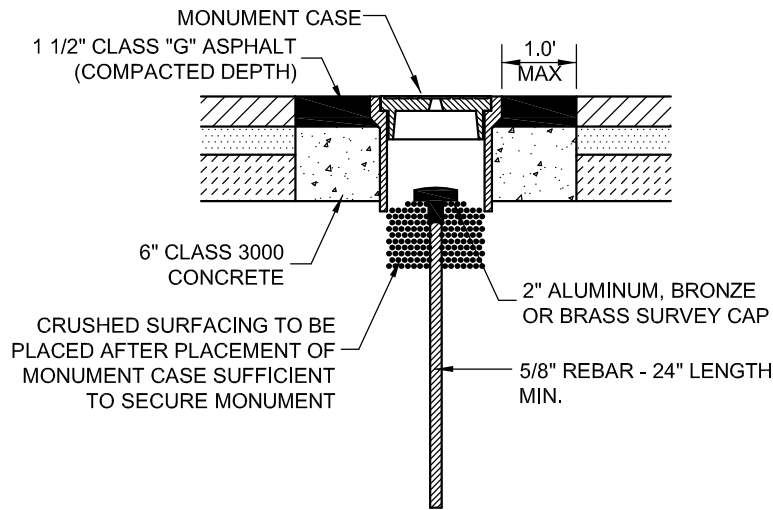

SECTION

NOTES

1. MONUMENT TO BE PLACED AFTER FIRST LIFT.
2. TOP OF MONUMENT CASE SHALL BE 1" BELOW TOP OF FIRST LIFT.
3. MONUMENT CASE TO BE PLACED AFTER FINAL LIFT OF ASPHALT.
4. IN UNIMPROVED ROADS, THE MONUMENT CASE SHALL BE SET WITH THE TOP OF THE CASE 6" BELOW EXISTING GRADE.
5. WSDOT CLASS 3000 CONCRETE WITH AGGREGATE GRADING NO. 5.

