

PLAN VIEW

**NOTES:**

1. PRECAST ADJUSTMENT SECTIONS SHALL BE LEVELED WITH GROUT ONLY. SECTIONS SHALL BE FINISH GROUTED INSIDE AND OUT AND SHALL BE INSPECTED BY THE CITY ENGINEER PRIOR TO BACKFILL. NO WOOD SHIMS SHALL BE ALLOWED.
2. PIPES TO BE GROUTED IN PLACE. GROUT SHALL BE NON-GYPSUM TYPE GROUT AS APPROVED BY THE CITY ENGINEER.
3. NO PRIVATE LINE CONNECTIONS SHALL BE MADE INTO MANHOLES.
4. BASE IS TO BE CAST-IN-PLACE UTILIZING CL 4000 CONCRETE.

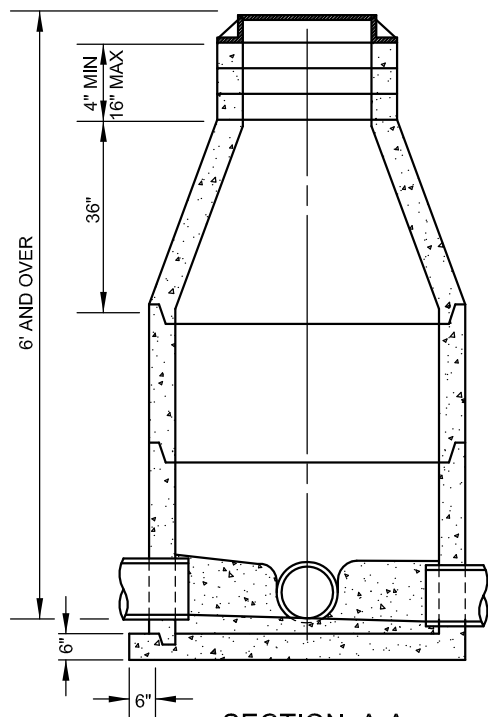

SECTION A-A

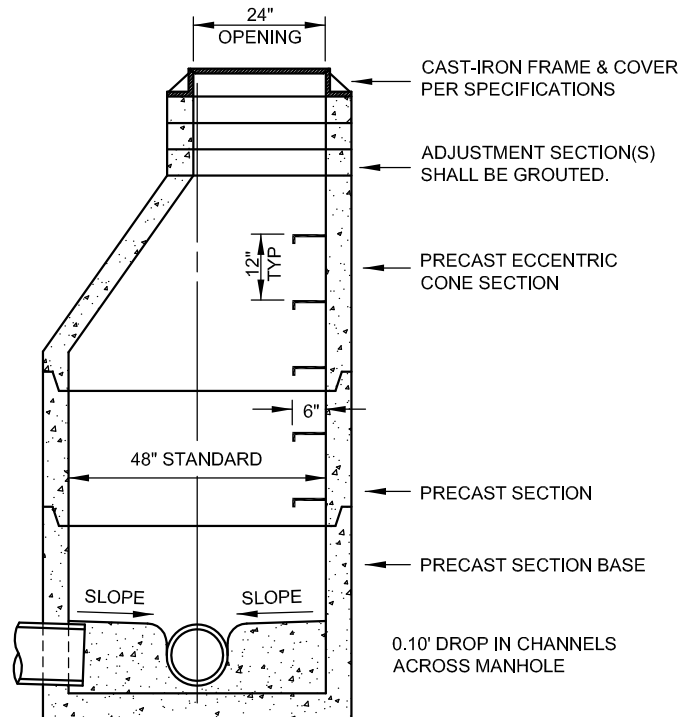

SECTION B-B



City Of Yakima  
Engineering Division

129 North Second Street  
Yakima, Washington

City of Yakima - Standard Detail

**SANITARY SEWER MANHOLE**

**S1**

NOT TO SCALE  
Revision 05-2010