

COMMERCIAL APPROACH - TYPE 1

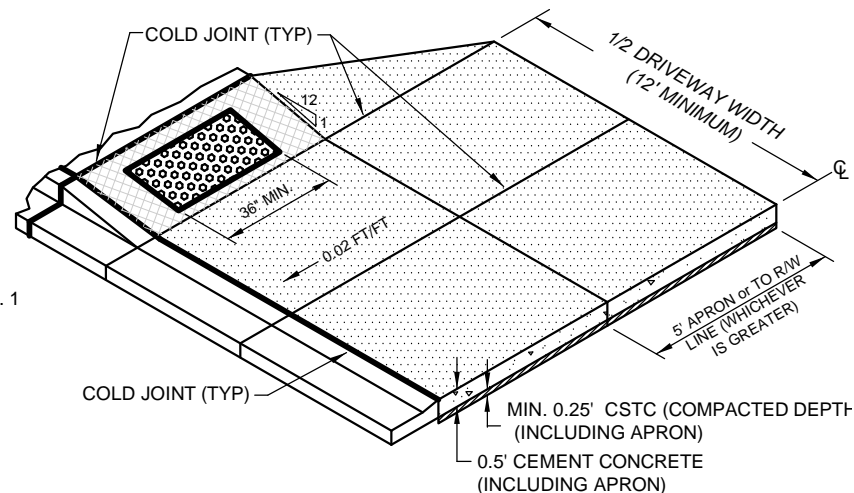

COMMERCIAL APPROACH - TYPE 2

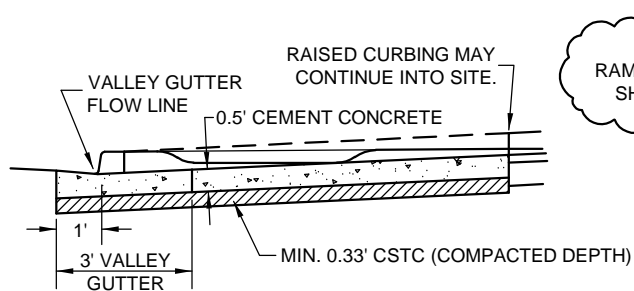

SECTION A

RAMP RUNNING SLOPES SHALL BE 8.3% MAX.

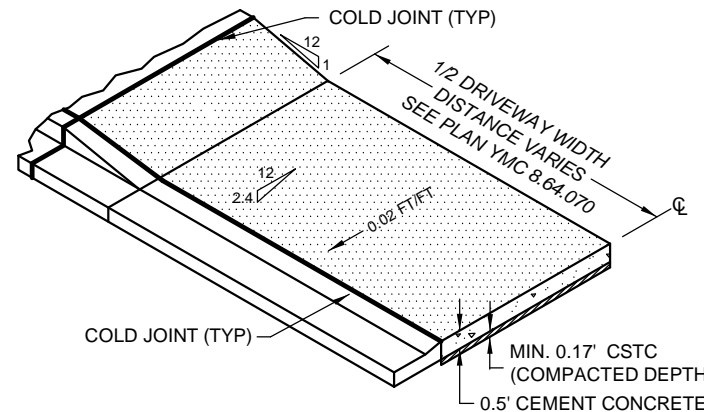
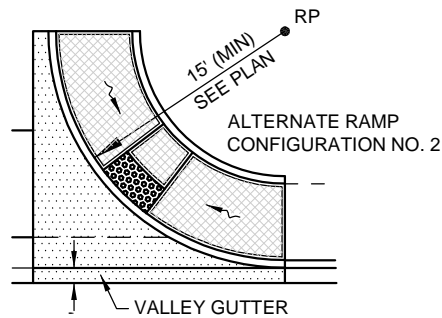

RESIDENTIAL APPROACH

- NOTES**
1. USE OF COMMERCIAL APPROACH - TYPE 2 BY APPROVAL OF CITY ENGINEER ONLY.
 2. CURB & GUTTER, VALLEY GUTTER, & CONCRETE APPROACH SHALL BE SEPARATED BY 3/8" THICK EXPANSION JOINT MATERIAL.
 3. THIS DETAIL INDICATES GENERAL CONFIGURATION REQUIREMENTS FOR COMMERCIAL DRIVEWAY APPROACHES. STYLE AND LOCATION OF HANDICAP RAMPS WILL DEPEND UPON SITE CONDITIONS AND SHALL BE CONSTRUCTED ACCORDING TO THE SPECIFIC PROJECT SITE PLAN APPROVED BY THE CITY ENGINEER.
 4. WSDOT CLASS 3000 CONCRETE WITH COARSE AGGREGATE GRADING NO. 5.
 5. DUE TO THE MINIMUM SIZE RADIUS OF 15', SPECIAL CONSIDERATIONS NEED TO BE MADE TO ALLOW FOR ADA REQUIREMENTS ON THE RAMPS. 15' RADIUS DESIGNS MUST BE SUBMITTED AND APPROVED BY THE CITY ENGINEER PRIOR TO CONSTRUCTION.
 6. ALL SIDEWALK WITHIN COMMERCIAL APPROACH LIMITS, FROM RADIUS POINT TO RADIUS POINT, SHALL BE 0.5' CEMENT CONCRETE ON 0.33' CSTC.



**City Of Yakima
Engineering Division**

129 North Second Street
Yakima, Washington

City of Yakima - Standard Detail
DRIVEWAY APPROACHES

NOT TO SCALE
Revision 11-2011

R4